

Le rando-guide

» Principe

Le principe est simple, ce rando-guide vous indique pour chaque intersection la direction à suivre...

A vous de retrouver votre chemin pour boucler la boucle...

Vous trouverez dans les premières pages de ce guide une légende.

» Il est vivement conseillé de disposer d'un compteur et d'une carte IGN.

Respectez le code de la route, la nature, les plantations.

Le port du casque est conseillé.

Rando-Guide des Cluses



www.biKING66.com



VTT Pour Tous
16 rue de la mairie
66300 Saint Jean Lasseille
04 68 21 69 59

ufolep







LEGENDE

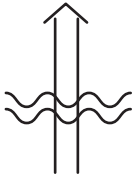

	Route		Direction à suivre
	Piste large		Mauvaise direction
	Sentier		Batiment
	Pont		Clôture
	Riviere		Objet remarquable
			referez vous au
			texte souligné

ORGANISATION DES PAGES

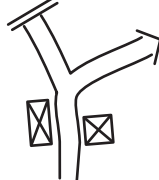
rando-guide des Cluses 2005			
Kilometrage total	Kilometrage partiel	Schema de l'intersection	Texte descriptif si nécessaire

www.biKING66.com

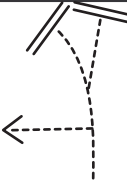
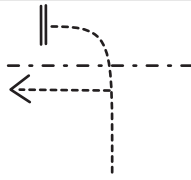
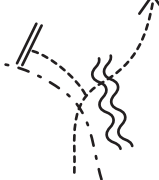
0,02	0,02		
0,15	0,13		
0,25	0,10		
0,43	0,18		
0,58	0,15		

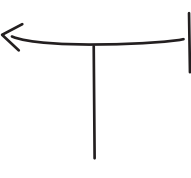
2,80	0,26		
3,05	0,25		Suivre la clôture
3,07	0,02		Traverser le lit de la riviere
3,30	0,23		Suivre le sentier sur le bord de la clairiere
3,44	0,14		

6		rando-guide des Cluses 2005	
0,77	0,19		
1,00	0,23		
1,91	0,91		
2,25	0,34		
2,54	0,29		Attention les parcours se séparent ici

8		rando-guide des Cluses 2005	
3,54	0,10		
3,63	0,09		
3,94	0,31		
4,51	0,57		
4,58	0,07		Vous devez être sous l'autoroute

rando-guide des Cluses 2005			33
53,15	0,33		
53,52	0,37		
53,82	0,30		
54,26	0,44		
54,39	0,13		Arrivée à gauche après le passage à gué

32 rando-guide des Cluses 2005

51,39	0,45		
52,33	0,94		
52,57	0,24		
52,75	0,18		
52,82	0,07		Le sentier plonge à gauche avant le virage

rando-guide des Cluses 2005 **9**

4,98	0,40		
5,28	0,30		Emetteur
6,99	1,71		
7,46	0,47		
7,86	0,40		

30 rando-guide des Cluses 2005

47,4	1,02		
48,69	1,29		Suivre le sentier qui passe entre l'arbre et le réservoir
48,86	0,17		
48,97	0,11		
49,03	0,06		

rando-guide des Cluses 2005 **11**



8,88	0,04		Rester en haut en suivant le bord droit
8,91	0,03		Descendre le long de l'arbre mort tombé au sol
8,97	0,06		
9,00	0,03		
9,05	0,05		Attention vous entrez dans un parc les piétons ont la priorité Entre les haies



10		rando-guide des Cluses 2005	
8,06	0,20		
8,19	0,13		
8,48	0,29		
8,59	0,11		Ce sentier n'est pas tres visible
8,84	0,25		Prendre le sentier à droite en face des <u>cypres</u>



rando-guide des Cluses 2005		31	
49,53	0,50		Variante free-ride à gauche
49,62	0,09		
49,69	0,07		
50,40	0,71		Citerne
50,94	0,71		Restez sur la piste principale

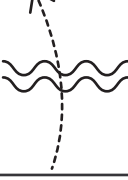
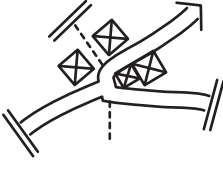

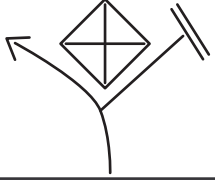
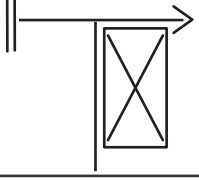
12		rando-guide des Cluses 2005	
9,14	0,09		A la sortie des <u>haies</u>
9,17	0,03		
9,22	0,05		
9,37	0,15		
9,43	0,06		

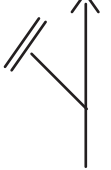
rando-guide des Cluses 2005		29	
45,81	0,07		
45,84	0,03		
46,11	0,27		
46,24	0,13		
46,38	0,14		

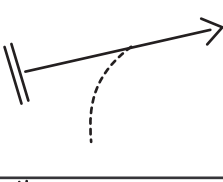
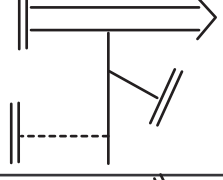
28		rando-guide des Cluses 2005	
43,95	1,86		Le sentier plonge à droite apres quelques metres sur la piste
44,73	0,78		
45,47	0,74		
45,54	0,07		
45,74	0,20		

rando-guide des Cluses 2005		13
9,48	0,05	
9,62	0,14	
9,76	0,14	
9,80	0,04	
11,92	2,12	

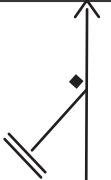
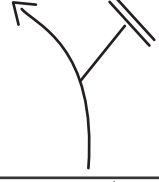
26		rando-guide des Cluses 2005	
33,88	0,21		
34,00	0,12		
34,28	0,28		
34,45	0,17		
35,35	0,90		Suivre la piste principale qui monte

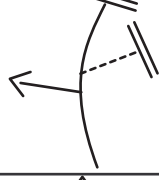
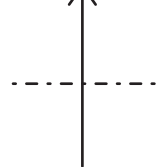

rando-guide des Cluses 2005		15	
15,16	0,64		Le 25Km arrive de la gauche <u>Cabane à chiens</u>
15,50	0,34		
15,61	0,11		
15,82	0,21		Attention les parcours se séparent ici RAVITAILLEMENT
15,93	0,11		

14		rando-guide des Cluses 2005	
13,40	1,48		Attention les parcours se séparent ici
13,72	0,32		
14,08	0,36		
14,17	0,09		
14,52	0,35		

rando-guide des Cluses 2005		27	
36,77	1,42		
37,42	0,65		
38,15	0,73		
41,46	3,31		Le depart de la descente est dans les fougères
42,09	0,63		

16		rando-guide des Cluses 2005	
16,11	0,18		
16,51	0,4		
16,72	0,21		
17,03	0,31		
17,15	0,12		Réservoir

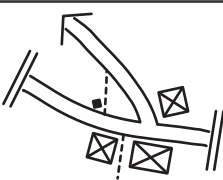
rando-guide des Cluses 2005		25	
31,22	1,00		
31,68	0,46		
31,79	0,11		
32,03	0,24		
33,67	1,64		

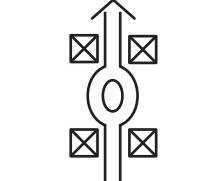
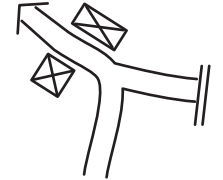
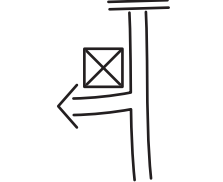
24		rando-guide des Cluses 2005	
29,66	0,32		Prendre le sentier à droite du <u>pressoir</u>
29,79	0,13		
29,94	0,15		
30,12	0,18		
30,22	0,10		Attention apres 13h vous serez arreté ici

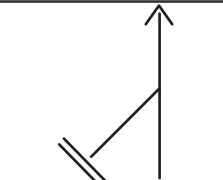
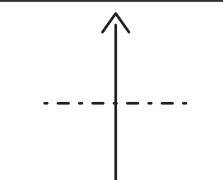
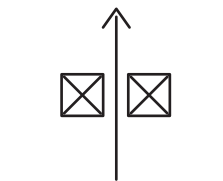
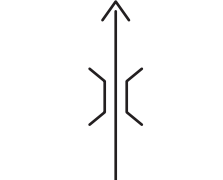
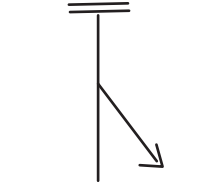
rando-guide des Cluses 2005		17	
18,01	0,86		
18,03	0,02		
18,57	0,54		
18,65	0,08		
19,43	0,78		

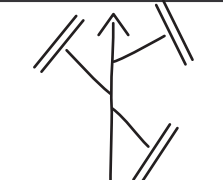
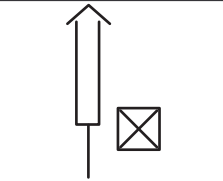
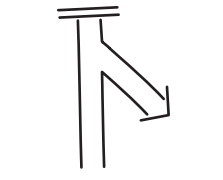
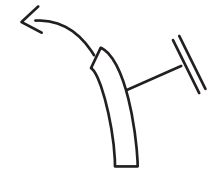
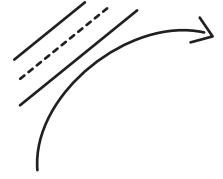
22		rando-guide des Cluses 2005	
24,63	0,06		
25,28	0,65		
26,19	0,91		
26,79	0,60		
26,83	0,04		Passage à proximité de l'autoroute

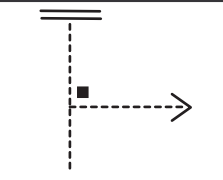
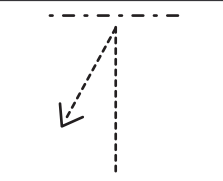
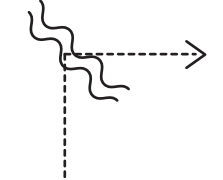
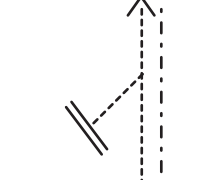
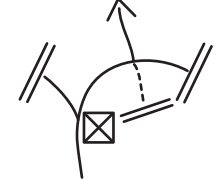
rando-guide des Cluses 2005		19	
20,77	0,36		Attention les parcours se séparent ici <u>Chene liege</u> remarquable
21,20	0,43		Avant la clôture descendre à gauche vers la riviere
21,25	0,05		Attention tra-versez la riviere à pied
21,38	0,13		
21,48	0,10		

18		rando-guide des Cluses 2005	
19,79	0,36		Attention le 25Km arrive en face
19,92	0,13		
19,99	0,07		
20,03	0,04		
20,41	0,38		

rando-guide des Cluses 2005		23	
27,89	1,06		
28,66	0,77		Passage sous l'autoroute
28,83	0,17		
29,18	0,35		A la sortie de l'épingle prendre la via Domitia
29,34	0,16		Reprendre la via Domitia immédiatement à droite apres le <u>muret</u>

20		rando-guide des Cluses 2005	
21,75	0,27		
21,99	0,24		
22,36	0,37		
23,01	0,65		
23,05	0,04		Ces deux sentiers sont peu visibles

rando-guide des Cluses 2005		21	
23,17	0,12		Attention le 25Km arrive de la gauche
23,19	0,02		
23,30	0,11		
24,28	0,98		
24,57	0,29		